



MARINE HOOKS

Off-Load, Quick Release Type
Open Boat Mounted
Pull-Cable (Lanyard) Release
Positive Lock Feature

Model:
70-DPR-856-C4B

INSTRUCTIONS

Table of Contents

Specification Sheet	1 Page
Installation Instructions	2 Pages
Instructions for Use	2 Pages
Service Program & Instructions	5 Pages
Inspection & Service Report	1 Page

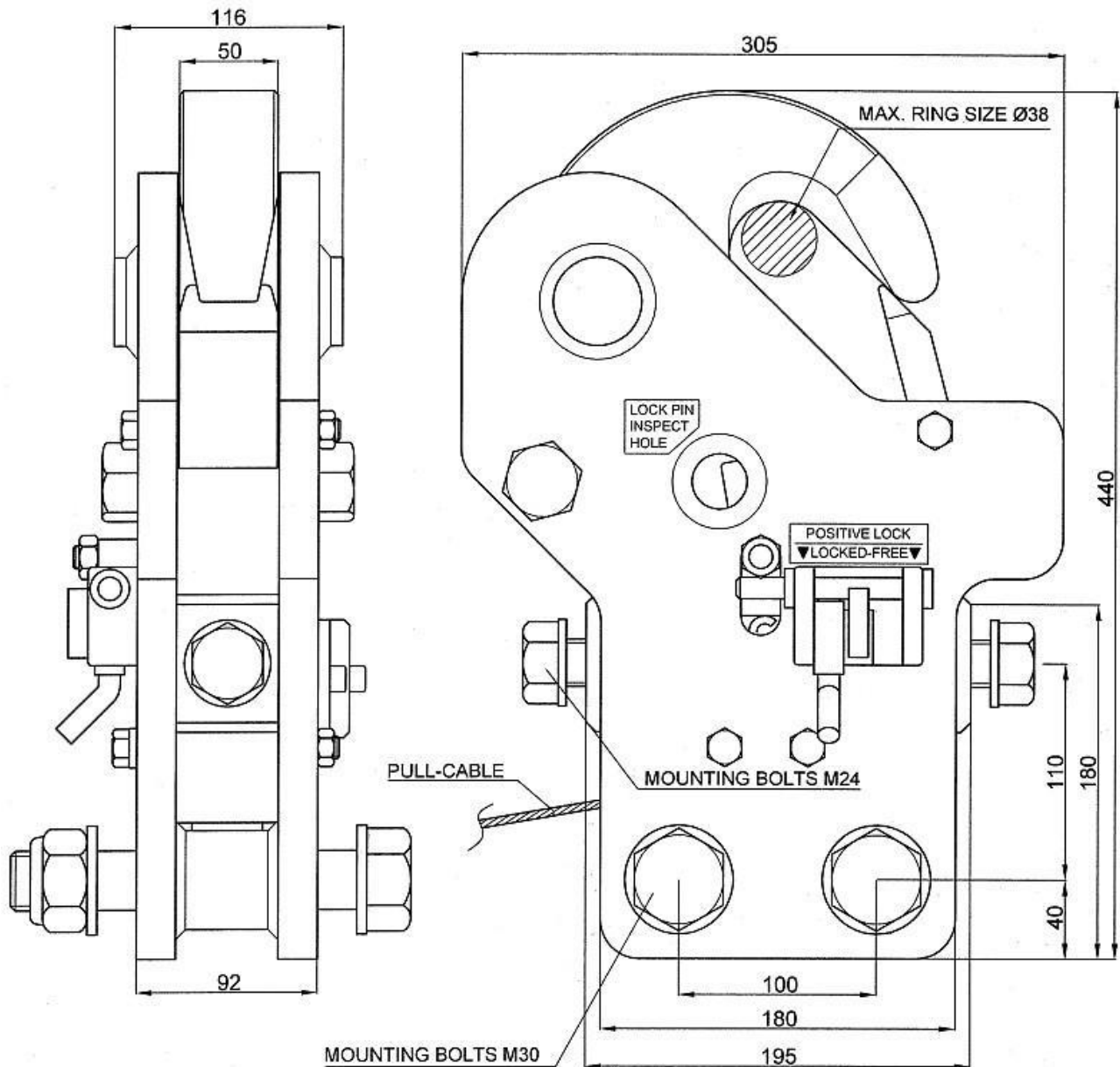

"C-E" Marine Hook, Off-Load type

Model: 70-DPR-856-C4B

100% Stainless

Cable release, Boat mounted

SWL/WLL: 8500 kg (6:1) Weight: 47 kg

Fitted with positive lock feature.

INSTALLATION INSTRUCTIONS

1. HOOK ASSEMBLY MOUNTED TO A BOAT MOUNTED LIFTING FRAME

C-E hook styles 60 & 70 are designed for mounting to a hook mounting bracket on a boat mounted lifting frame, and are attached with mounting bolts at the lower part of the hook assembly. The rotating hook piece is in the top position. The number of mounting bolts used is determined by the hook style and capacity.

VERY IMPORTANT !

The lift ring (when engaged in the Hook) is on the top side of the hook assembly which means that the lift ring may lay over in different positions when slack, and may foul in the hook, resulting in damages to the hook. It is therefore important to size the lift ring with this possibility in mind.

2. PULLING FORCE AT RELEASE, OFF-LOAD HOOKS

C-E marine hooks are made to release ONLY when there is NO LOAD on the hook piece, and therefore the term OFF-LOAD applies. There is a negative angle at the "locking faces" of the hook piece and lock pin which prevents the Hook from being OPENED when a force of approx. 100 kg (220 lbs) is present and the "locking faces" are fully engaged. Pulling force to cause release is approx..15 kg (35 lbs) when there is no load on the hook.

3. LIFT RINGS

"C-E" marine hooks are designed for use with lift rings which have a ROUND cross-section. Lift rings should not be used which have OVAL cross-section, or rings which are too large in diameter and do not pass freely through the hook latch when the hook is CLOSED.



MARINE HOOKS

Page 2 of 2

INSTALLATION INSTRUCTIONS (continued)

4. REMOTE RELEASE CONTROL

In case the hook pull-cable (lanyard) is to be attached to a release lever, rope extension, or any type of remote operator, the arrangement must not allow any pre-loading on the pull-cable, as this may prohibit the lock pin from fully engaging the hook piece "locking face". Fouling of the pull-cable in surrounding structures must also be avoided.

Under no circumstances shall the pull-cable be subjected to a "pre-loaded" condition in the mounting arrangement !

VERY IMPORTANT !

The "locking faces" of the hook piece and lock pin must be FULLY ENGAGED when the hook is CLOSED. A sudden shock load may cause the boat to fall if the "locking faces" are not fully engaged when handling the boat on the hook.

(The "locking faces" may be viewed through Inspection holes on both hook sides)

DO NOT USE THE HOOK IF THE LOCK PIN AND HOOK PIECE ARE NOT FULLY ENGAGED WHEN THE HOOK IS IN THE CLOSED POSITION !

INSTRUCTIONS FOR USE**1.0 HOOKING-ON AT BOAT RECOVERY:**

Operations 1.1, 1.2, & 1.3 below, should be done BEFORE the lift ring is dropped for boat recovery !! Stay clear of swinging ring !!

1.1 Control that the sliding positive lock lever is in the FREE to release position. (The locking lever is in the FREE position when in the right hand slot)

1.2 Rotate the hook piece to the CLOSED position. There should be "snap" sound when the hook is closed. Control that the hook lock pin is fully engaged with the hook piece. (View through the lock pin inspection holes on the hook side plates)

Note: The hook may not be CLOSED if the positive lock is in the LOCKED position.

VERY IMPORTANT !

The "locking faces" of the hook piece and lock pin must be FULLY ENGAGED when the hook is CLOSED. A sudden shock load may cause the boat to fall if the "locking faces" are not fully engaged when handling the boat on the hook. (The "locking faces" may be viewed through inspection holes on both hook sides)

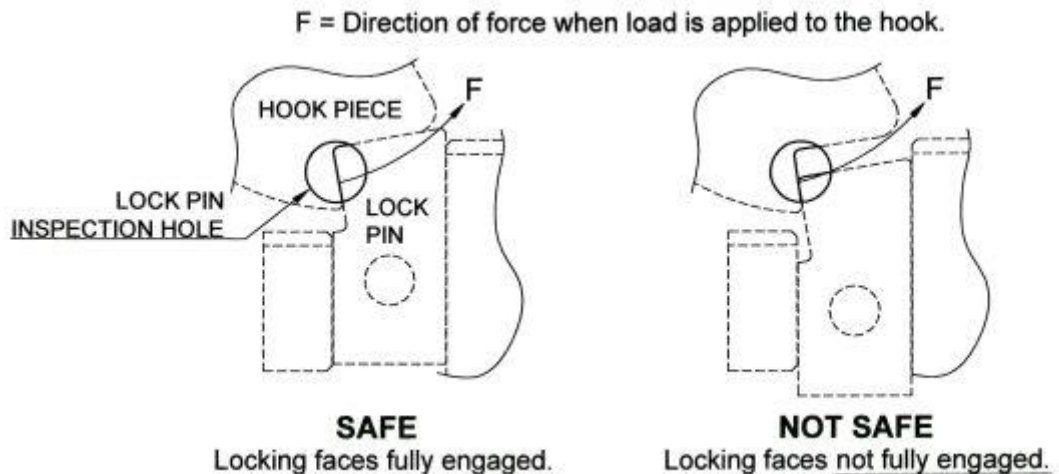

DO NOT USE THE HOOK IF THE LOCK PIN AND HOOK PIECE ARE NOT FULLY ENGAGED WHEN THE HOOK IS IN THE CLOSED POSITION !

INSTRUCTIONS FOR USE (continued)

1.0 HOOKING-ON AT BOAT RECOVERY (continued)

- 1.3 Move the locking lever to the LOCKED position (Lift the locking lever, rotate upwards 90 degrees, move the lever to the left hand slot and release).

The hook is now in POSITIVE LOCK MODE and MAY NOT BE RELEASED as the locking lever prevents the hook lock pin from being operated by the pull-cable (lanyard)

- 1.4 Always place the lift ring into the hook through the hook latch, keep your fingers clear and take care that the ring does not foul in the hook. If all other boat recovery procedures are in order, the boat is ready to be lifted. **PROCEED WITH CAUTION AND OBSERVE ALL SAFETY PROCEDURES !!**

2.0 BOAT LAUNCH PROCEDURE

- 2.1 Check the position of the positive lock lever. It should be in the LOCKED position at all times when the boat is more than 1-2 meters above the water. (See 1.3 above) Check that the hook lock pin is fully engaged with the hook piece, and that the lift ring is securely in place and not fouled in the hook.

- 2.2 Just prior to, or as the boat becomes waterborne, move the locking lever to the FREE to release position (to the right)

- 2.3 Grasp the pull-cable or release lever and pull sharply when the lift ring goes slack in the hook. Keep pulling on the cable until the hook piece rotates to the OPEN position and the lift ring is clear of the hook. Follow prescribed operating procedures to complete the launch.

Remember that the hook CAN NOT be opened until there is no load on it.

The lift ring must go slack first !! Beware of swinging lift ring at release !!

PROCEED WITH CAUTION AND OBSERVE ALL SAFETY PROCEDURES !!

**SERVICE PROGRAM AND INSTRUCTIONS
HOOK MODEL: 70-DPR-856-C4B**

The following inspection and service is to be done at intervals given by OEM (Original Equipment Manufacturer), or at any time the hook does not function properly. (Refer to drawing, page 5 and inspection & service report)

Interval**Procedure**

Every time hook is used

Check visually that the hook is complete and without any dents or bends.

Monthly

1. If needed clean the hook with solvent and warm water.
2. Lubricate the hook axle and lock pin with light machine oil, silicon spray or antifreeze in freezing weather. **DO NOT USE GREASE!**
3. Check that the hook piece rotates freely between open and closed position, and that the lock pin moves freely when opening and closing the hook.
4. Check through the inspection holes on the hook sides that the "locking faces" of the hook piece and lock pin is fully engaged when the hook is closed.

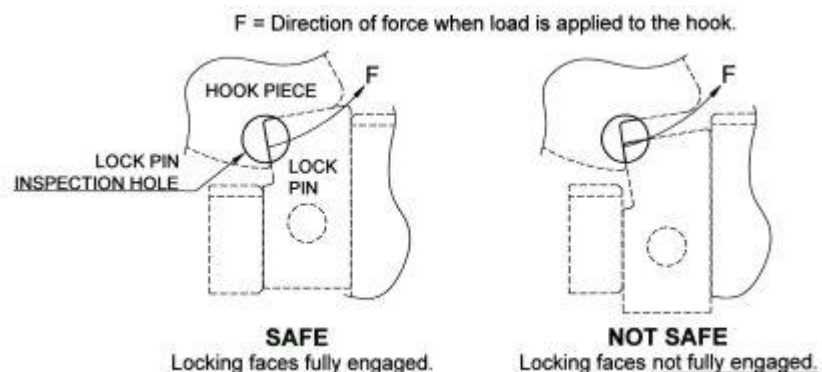

If the lock pin does not fully engage with the hook piece or otherwise operates in a sluggish manner, the lock pin spring must be replaced immediately!

DO NOT USE THE HOOK IF THE LOCK PIN AND HOOK PIECE ARE NOT FULLY ENGAGED WHEN THE HOOK IS CLOSED!

5. Inspect the surface of the locking faces that there are no notches or wear. **The hook must be taken out of use and sent to OEM if any damages at the locking faces are present!**

Interval**Procedure**

Monthly (cont.)

6. Inspect hook piece wear. If obvious wear detected, contact OEM.

7. Inspect the pull-cable for free movement and damages. Replace if damaged. (See instructions, page 4)

8. Check the latch operation. The latch should operate in a sharp way and touch the hook “nose” when the hook is closed. When the hook is opened the latch should stay tight against the limit. **If the latch does not operate properly, the latch springs must be replaced immediately!**

9. Inspect the mounting bolts for defects and ensure proper tightening.

10. Inspect the lift rings used with the hook. Replace if damaged.

30 months

1. Replace the lock pin spring. (See instructions, page 3)

2. Replace the latch springs. (See instructions, page 3)

60 months

Send hook to OEM or other authorized service and testing facility for complete inspection, service, testing and re-certification.

PART REPLACEMENT INSTRUCTIONS**LOCK PIN SPRING (5) REPLACEMENT PROCEDURE**

Note: The hook should be demounted before attempting to replace parts.
See drawing on page 5 for part no. identification.

1. Loosen the bolts (3) on the spring cap (4), so that the tension of the lock pin spring (5) comes off.
2. Remove the bolts and the cap.
3. Remove the old lock pin spring through the spring cap hole and replace it with a new one.
4. Install spring cap (note hole for spring end) and put bolts in place.
5. Adjust the lock pin spring so that the pulling force to release the hook is approx. 15 kg.
6. Check the hook for proper operation.

LATCH SPRING (2) REPLACEMENT PROCEDURE

Note: The hook should be demounted before attempting to replace parts.
See drawing on page 5 for part no. identification.

1. Remove bolt & nut assembly (1), that holds the latch (9) in place.
2. Remove the latch and the old springs.
3. Install the new latch springs (2, 2pcs) so that the long end of the spring goes against the hook body and the short leg against the latch.
4. Check the hook for proper operation.

All spare parts must be ordered from OEM!

PULL-CABLE (8) REPLACEMENT PROCEDURE

Note: The hook should be demounted before attempting to replace parts.
See drawing on page 5 for part no. identification.

1. Open hook completely.
2. Remove nut, spacer and bolt (6).
3. Push lock pin (7) up and pull the old cable (8) out from the hook.
4. Push the new cable end (cut end only) between the rollers (10), and pull it out from the side so far that the cable eye end stays a bit out from the hook body.
5. Insert cable eye into the lock pin slot, and put a short (not wider than the lock pin) temporary pin in the lock pin hole through the cable eye.
6. Push lock pin into the hook body, while pulling slightly the slack away from the cable.
7. Insert the bolt (6) through the slot on hook side and through lock pin and cable eye, so that the temporary pin comes out. The bolt must be pushed in from the opposite side of the positive lock.
8. Put in place spacer (has to be on positive lock side) and new nyloc nut.
9. Check the hook for proper operation.

All spare parts must be ordered from OEM!

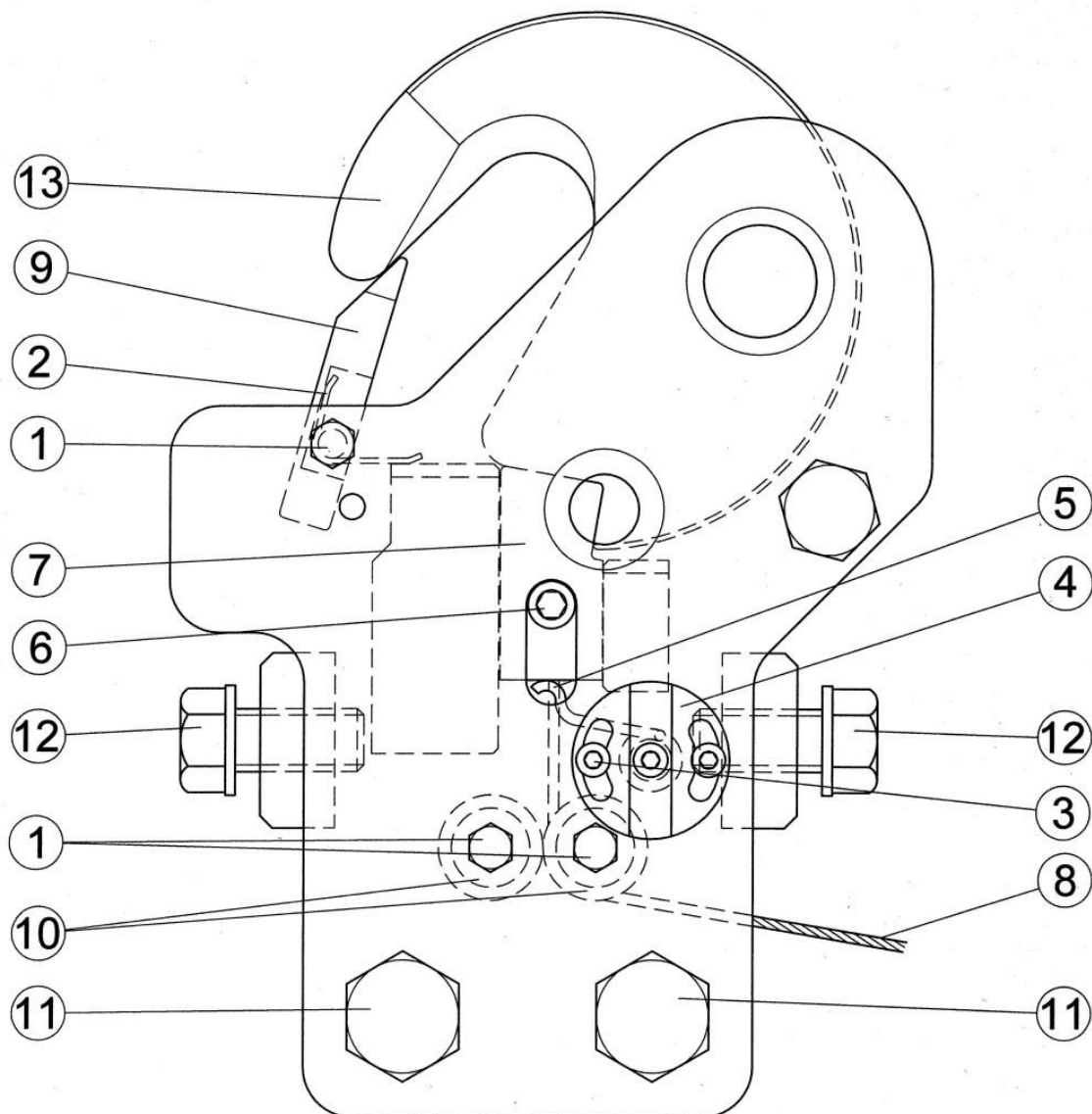
Part numbers & locations**PARTS LIST**

1. M10 bolt assembly (latch, rollers)
2. Latch spring, (2 pcs/hook)
3. M8 bolt (3 pcs/hook)
4. Spring cap
5. Lock pin spring
6. Lock pin bolt assembly
7. Lock pin
8. Pull-cable
9. Latch
10. Roller, (2 pcs/hook)
11. M30 Mounting bolt assembly, (2 pcs/hook)
12. M24 Mounting bolt assembly, (2 pcs/hook)
13. Hook part (can be changed only by OEM)



MARINE HOOKS

INSPECTION & SERVICE REPORT

Hook model: _____ Serial No: _____

Test Certificate No: _____ Date: _____

Installation position: _____ Date: _____

<u>Inspected & serviced</u>	<u>OK</u>	<u>Not OK</u>	<u>Remarks</u>
1. Cleaned	_____	_____	_____
2. Hook body damages	_____	_____	_____
3. Lubricated	_____	_____	_____
4. Free hook rotation	_____	_____	_____
5. Free lock pin movement	_____	_____	_____
6. Lock pin spring	_____	_____	_____
7. Lock pin wear	_____	_____	_____
8. Hook piece wear	_____	_____	_____
9. Pull-cable (if used)	_____	_____	_____
10. Hand lever (if used)	_____	_____	_____
11. Free latch movement	_____	_____	_____
12. Latch spring	_____	_____	_____
13. Latch adjustment (if possible)	_____	_____	_____
14. Mounting bolts	_____	_____	_____
15. Lift ring assembly	_____	_____	_____
16. Welds for cracks	_____	_____	_____
17. Other (list) _____	_____	_____	_____

Inspected by: _____ Date: _____

Scheduled for:	Next inspection & service	Date: _____
	Proof load test	Date: _____
	OEM hook inspection	Date: _____

Remarks and/ or suggestions: _____

