



9" DC AXIAL FAN - 12 VOLT

Part # 500-309121IP

The powerful 9-inch ignition protected DC axial fan is ideally suited for small vessel engine rooms and OEM applications. It has been designed and manufactured specifically for marine use. Excellent for today's high horse-power gas and diesel vessels.



AIRFLOWS TO 747 CFM

Design & Construction

Fans are specifically designed and built for the rigors of the marine environment. Excellent corrosion resistance and light weight. Universal powder coated bracket allows mounting in any orientation.

Motor

The motor is a totally enclosed (TEAO) double-shielded ball bearing type, and is constructed with die cast aluminum end plates, O-ring seals, stainless steel shaft and tough black Teflon epoxy coating for corrosion resistance.

Blower Blades & Housing

A ten blade glass filled nylon hub with a pilot is secured directly to the motor shaft. Hub/blade assembly is reversible for reversing the airflow. Fan airflow may be set up as a pusher or puller.

Performance

Continuous duty rated and ignition protected with airflows to 747 CFM at free air. CE Labeled with up to a 59% increase in airflow over the earlier types. Ignition proof construction, conforms to J1171, ISO 8846 and ISO 9097.

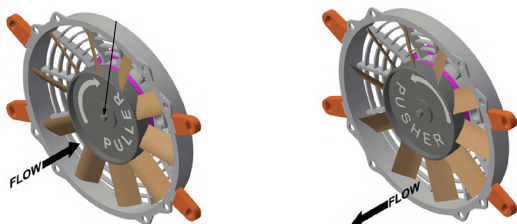
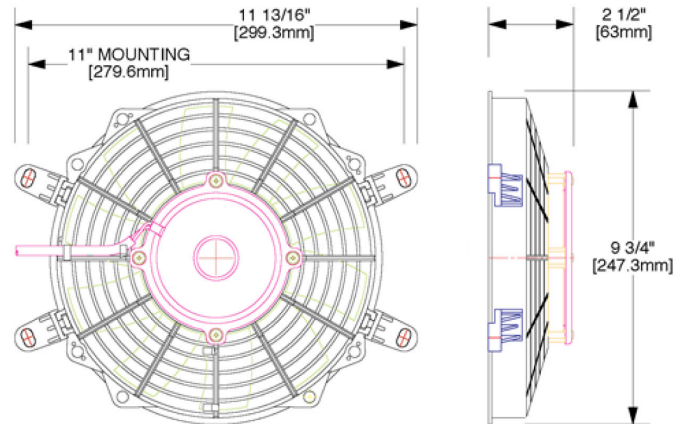
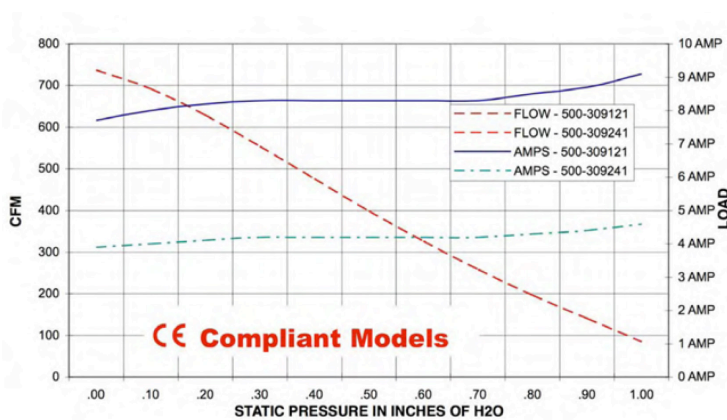

This fan airflow may be configured as a pusher or a puller fan. To reverse the airflow, simply remove and flip the fan blade/hub assembly and then reverse the polarity on the two power wires.